

Assembly instructions socket 24V 13/15pin according ISO 12098

Assembly contact holder

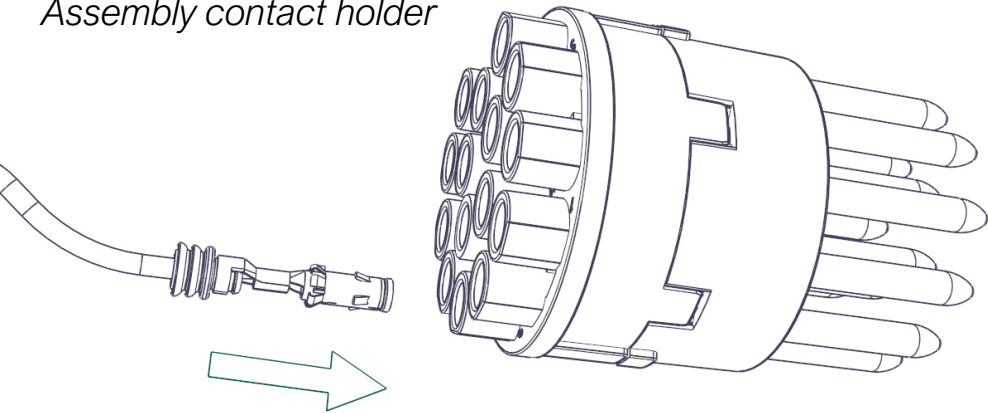

Insert the crimped socket contacts into the equipped contact holder and snap into place.
Assignment according to ISO 12098.

After the socket contacts have snapped into place, please check the correct assignment and locking.
If the spare parts kit is to be used for the 13-pin socket, slots 14 & 15 must be closed with the blind plugs.

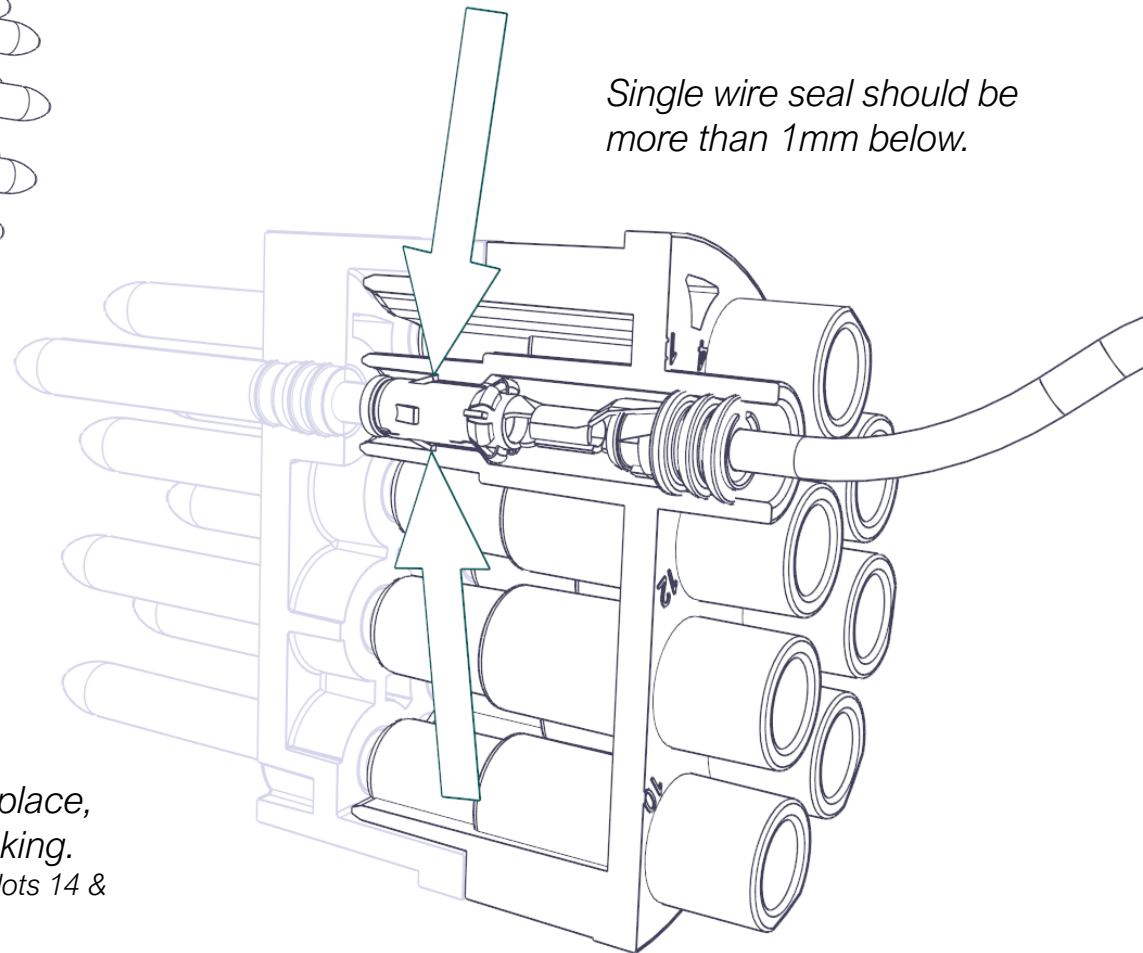

Single wire seal should be more than 1mm below.

Assembly instructions socket 24V 13/15pin according ISO 12098

Crimp

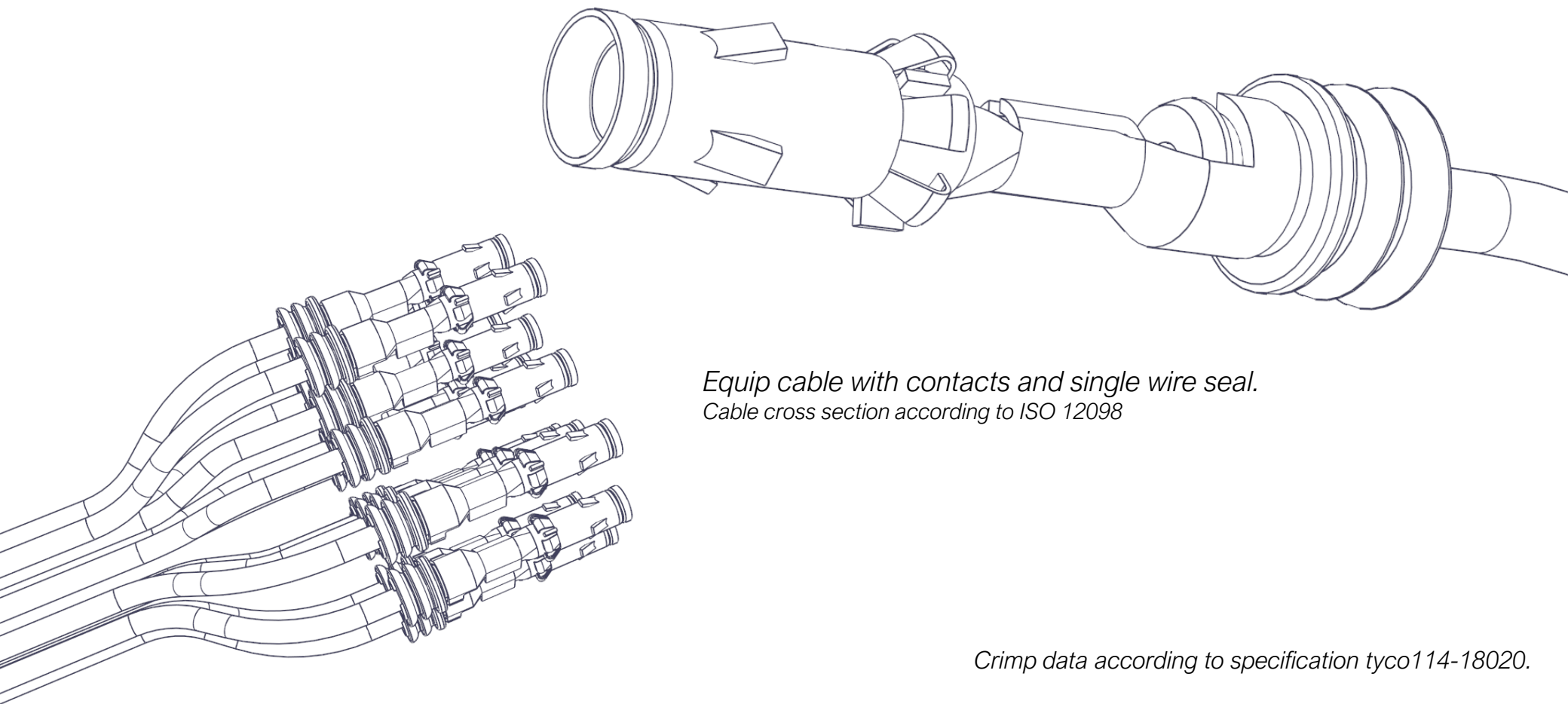

*Equip cable with contacts and single wire seal.
Cable cross section according to ISO 12098*

Crimp data according to specification tyco114-18020.

Assembly instructions socket 24V 13/15pin according ISO 12098

Assembly end cap / bayonet ring

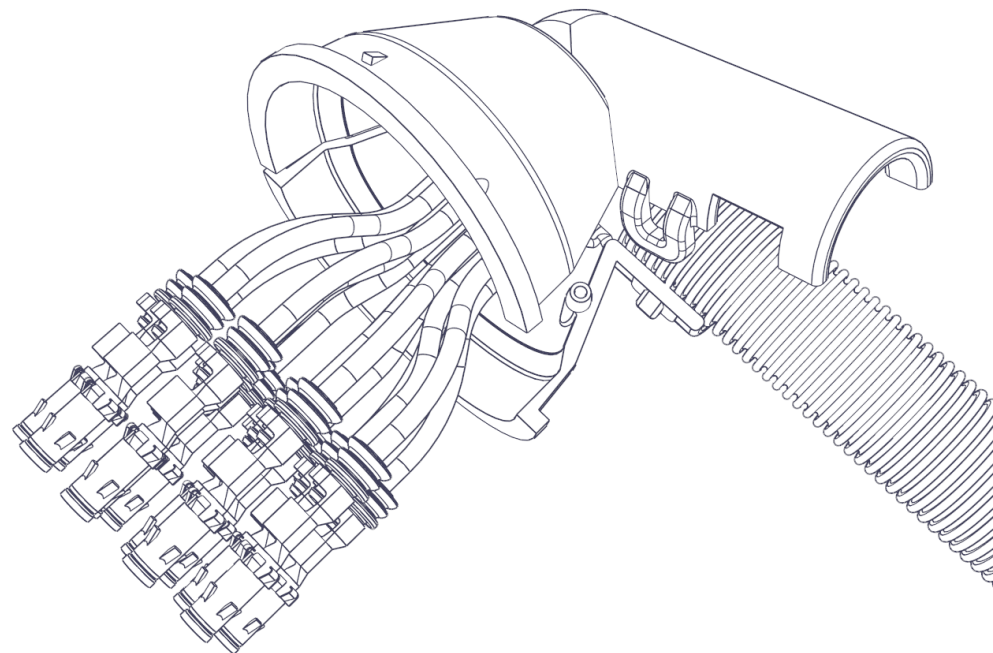
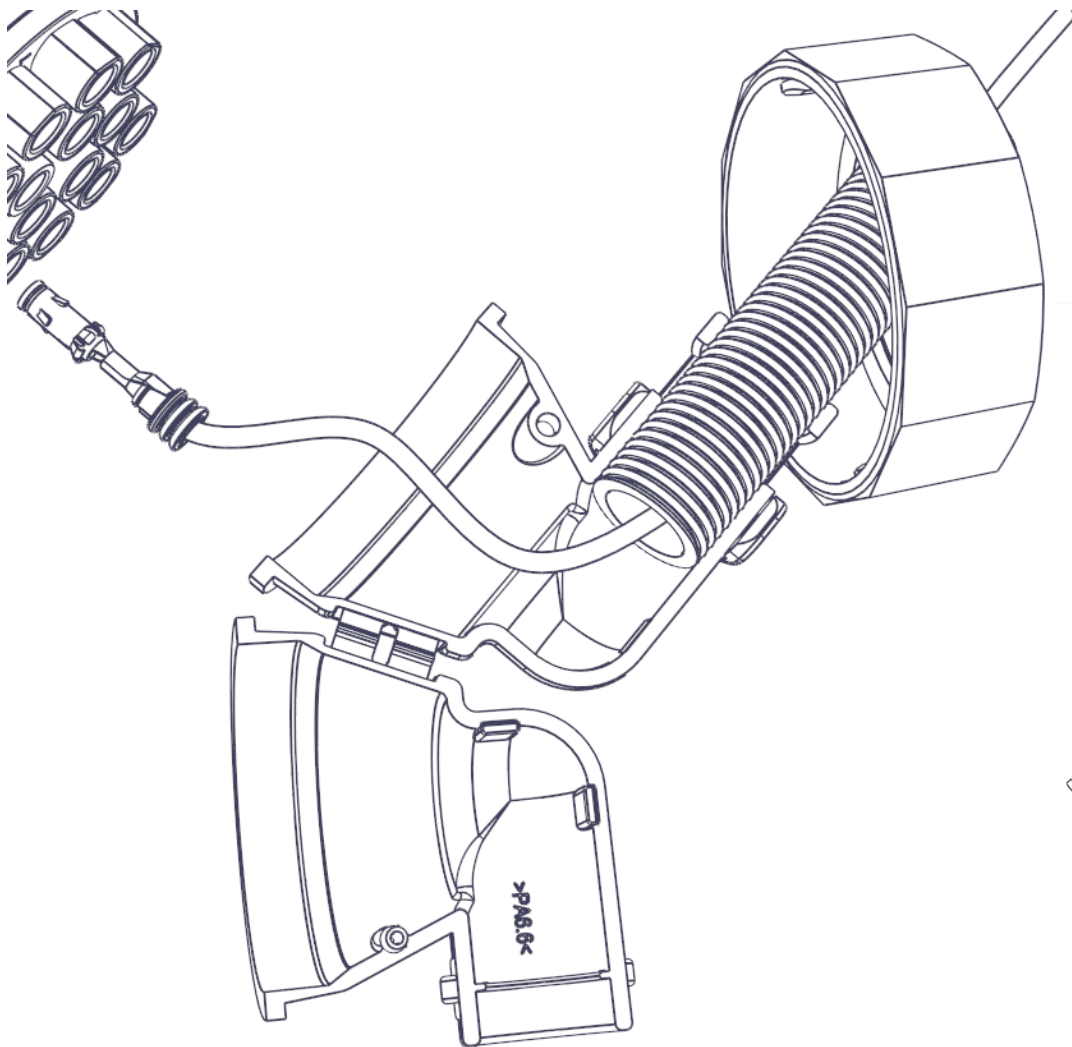

Assembly instructions socket 24V 13/15pin according ISO 12098

Assembly

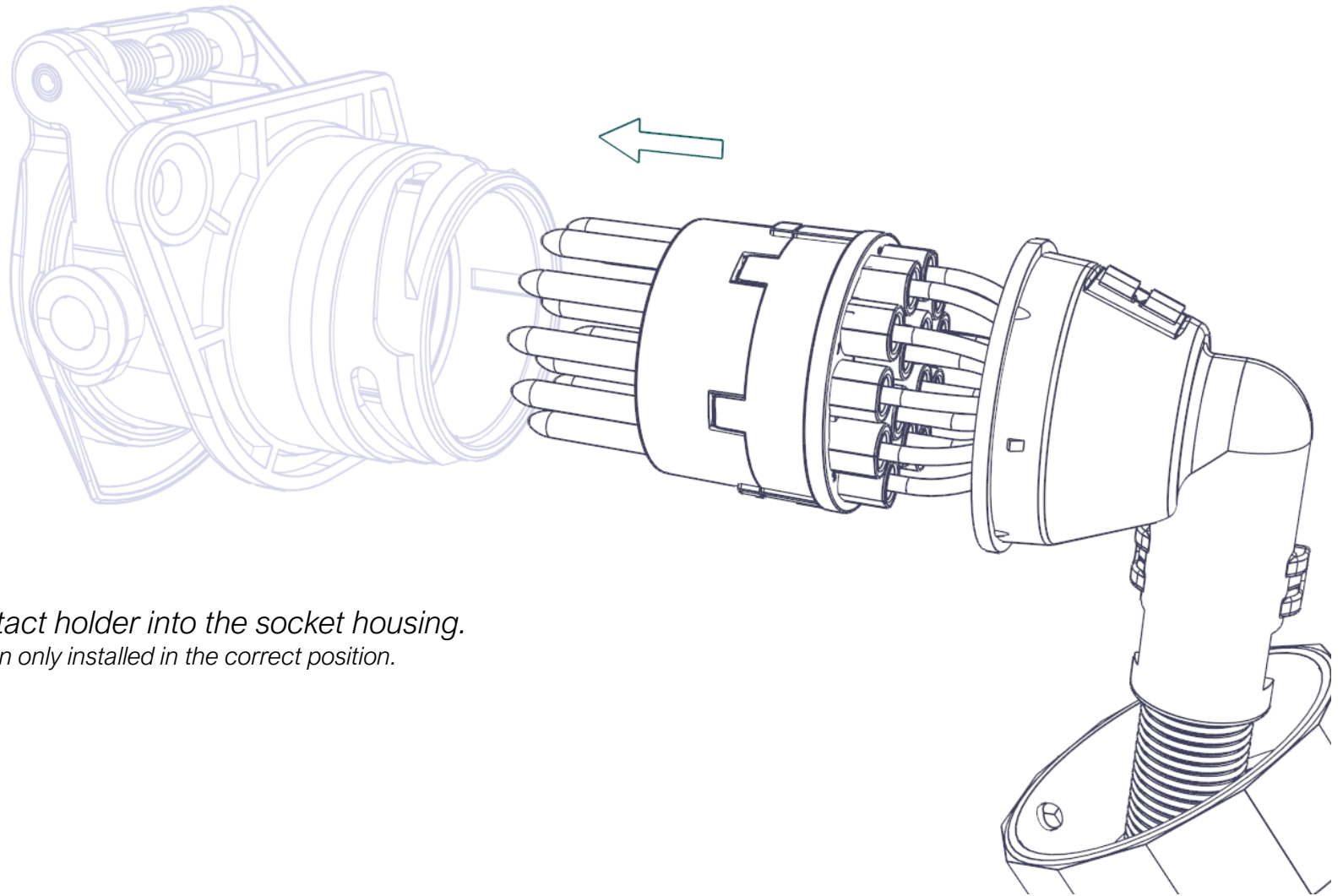

*Insert the contact holder into the socket housing.
Contact holder can only installed in the correct position.*

Assembly instructions socket 24V 13/15pin according ISO 12098

Assembly

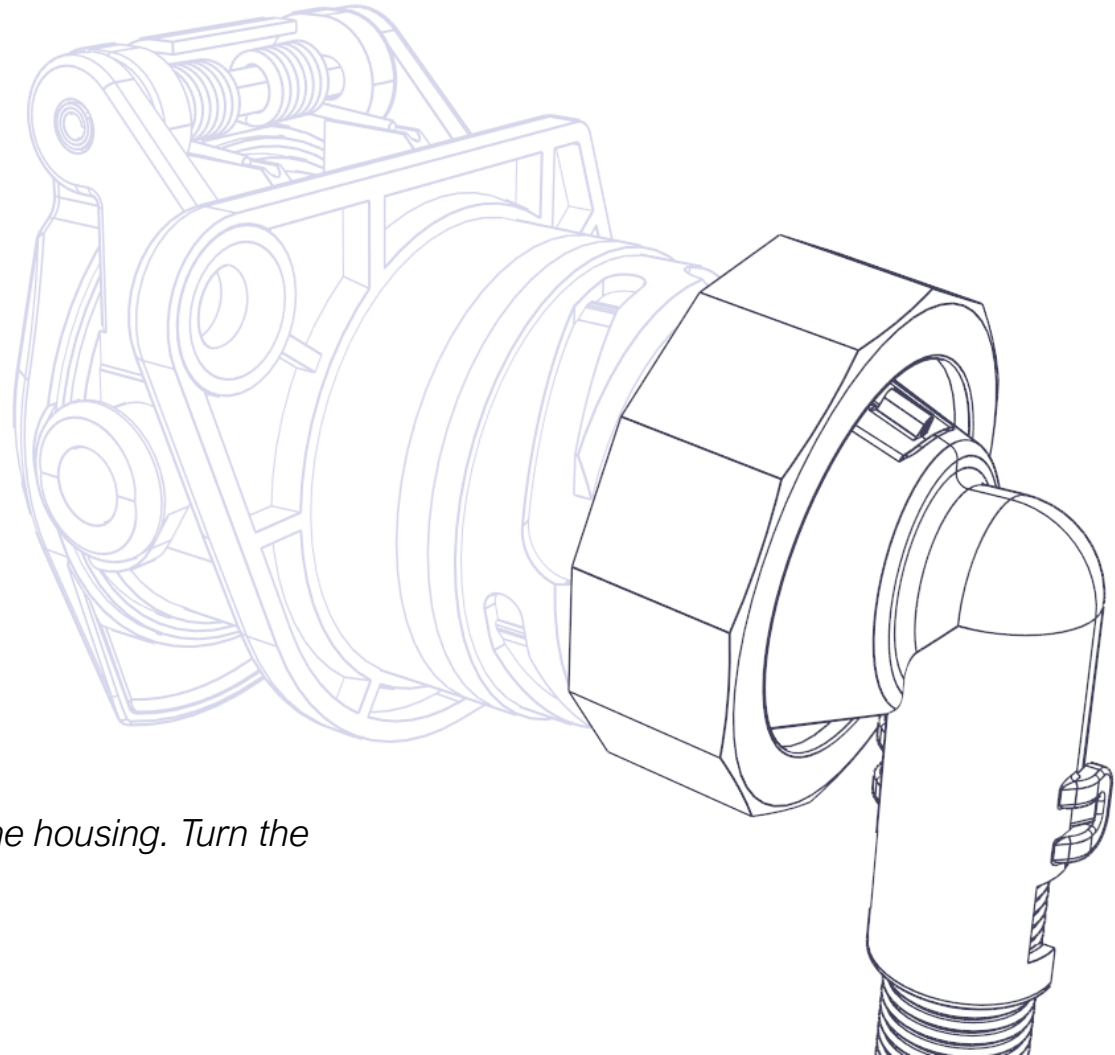

Slide the bayonet ring and end cap onto the housing. Turn the bayonet ring onto the housing. Bayonet domes have to lock into place.